

# Motorised Infrared Optical Beam Smoke Detector

## Additional Information

EN

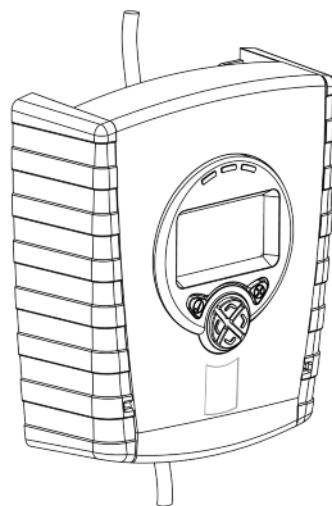
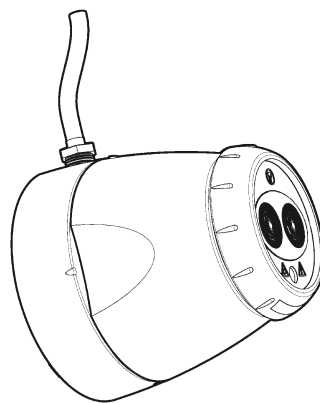

# 1. Multiple Zone Wiring

When wiring more than one System Controller to a single zone on a conventional Fire Control Panel (FCP) it is important to remember that if they are simply wired in series, if the first Controller goes into Fault state all remaining devices on the zone will be disconnected from the FCP, and if any these remaining devices subsequently go into Fire state this will be not be reported at the FCP.

If the FCP monitors for point detector removal, it is possible to use the following wiring diagram which uses diodes to provide zone continuity in the event of a Fault state on any Controller.

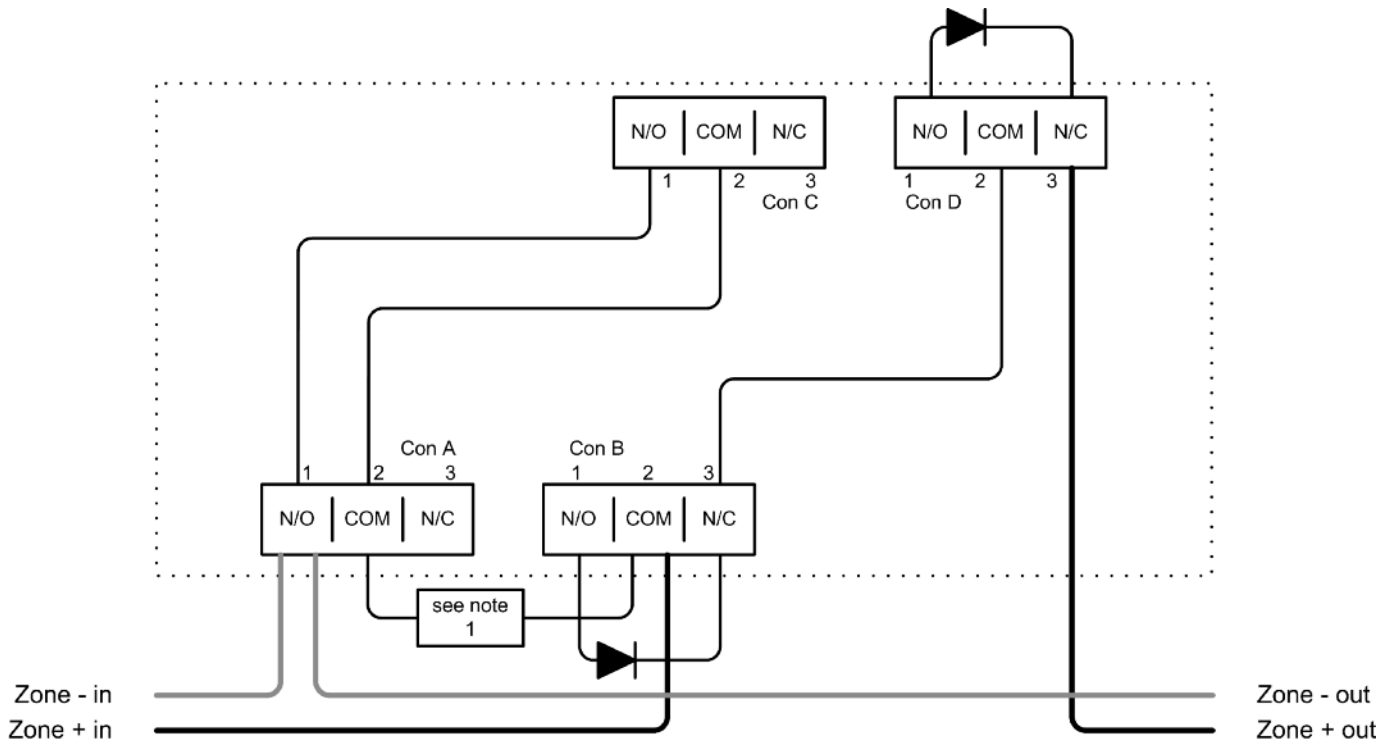

Note 1 – This component is the Fire Resistor. Its value is specified by the FCP manufacturer, and is not supplied with the System Controller. For U.S. installations it is typically a short circuit.

# 1. Multiple Zone Wiring (continued)

If the FCP does not monitor for detector removal, it is recommended that the following wiring diagram be used. For installations conforming to UL268 and NFPA72, the following diagram MUST be used when wiring multiple Controllers onto one zone.

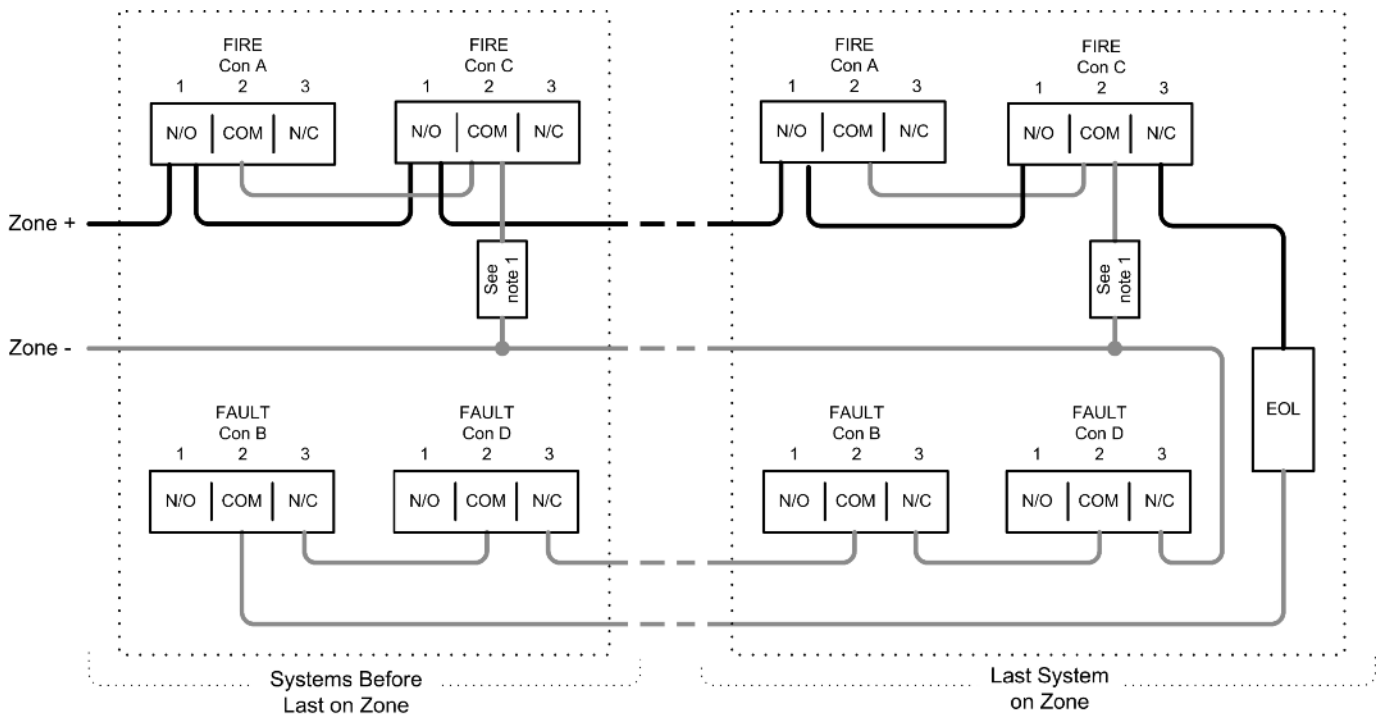

Note 1 – This component is the Fire Resistor. Its value is specified by the FCP manufacturer, and is not supplied with the System Controller. For U.S. installations it is typically a short circuit.

EOL – End of Line component. This is supplied with the FCP, and not supplied with the System Controller.

## 2. Event Logger

The System Controller contains a logging function which will store information for the most recent 50 events on each Detector.

To access the event log, press tick on the Event Logger icon when the relevant detector is highlighted:

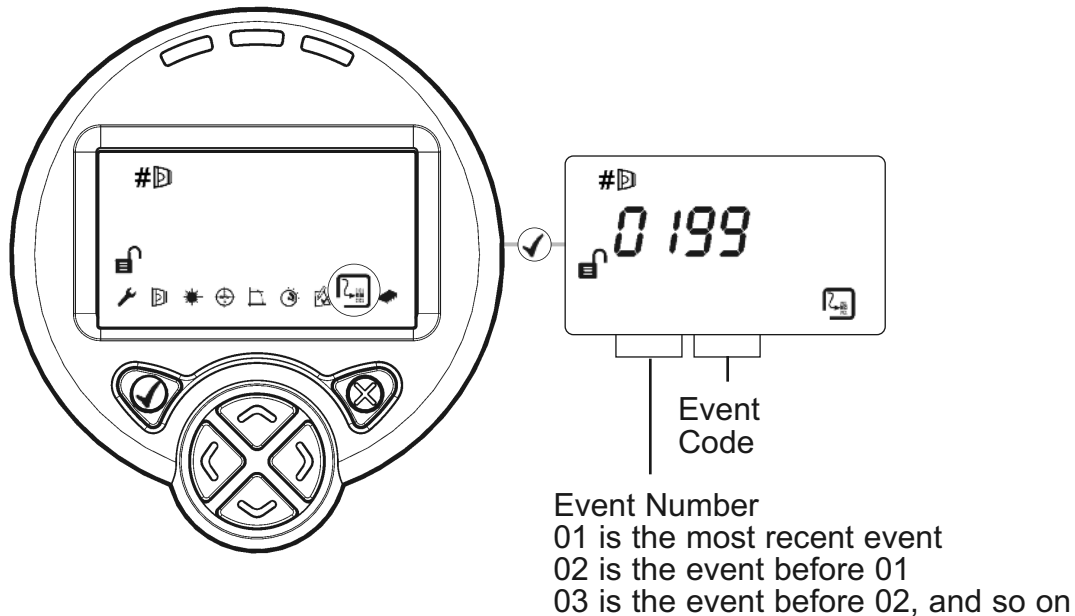

For each Fire or Fault activation, the controller will store:

- The event code – This is the same as the error code (E-\_\_) that would be displayed during the Fault, or one of the following:
  - 99 - Log erased
  - 98 - Power cycle
  - 97 - Fire Detected
  - 96 - Remote Fire Test initiated
  - 95 - AUTO initiated
  - 94 - LASER activated
  - 93 - 'Home' initiated
- The elapsed time since the event occurred
- The duration of the event
- The signal strength when the event occurred (if applicable)
- The AGC value when the event occurred (if applicable)

If there have been power-cycle events on the controller, all timing information will be lost for those events that occurred prior to the most recent of the power-cycles.

To erase and restart the event logger, press and hold 'left' and 'right' keys together when displaying any of the event log entries. Press 'tick' when prompted by 'SurE'.

## 2. Event Logger (continued)

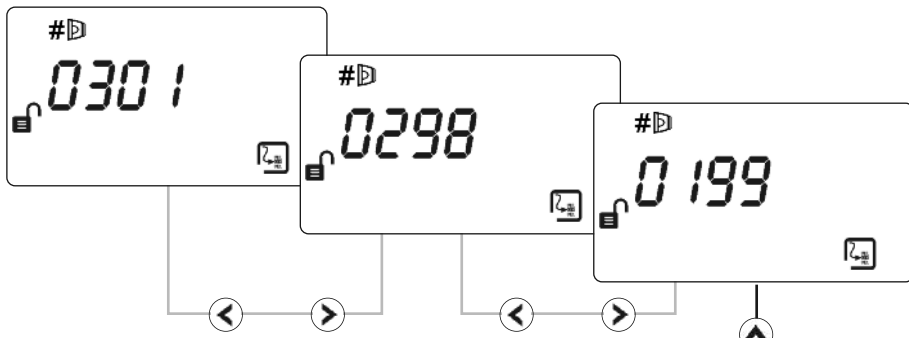

Press left to access older events, and right to access newer events. When the relevant event is selected, press down to access further information about the event.

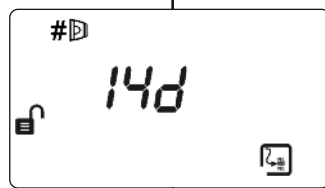

Time elapsed since event started. '—' will be displayed if the event occurred prior to the most recent power cycle.

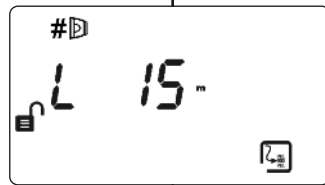

Duration of event. '—' will be displayed if the event is still occurring, or if a power cycle occurred while the event was in progress, or if there is no duration associated with the event type (e.g. power-on)

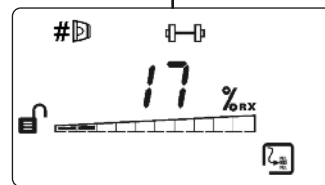

Signal strength when the event occurred. If the signal strength could not be read during the event '—' will be displayed.

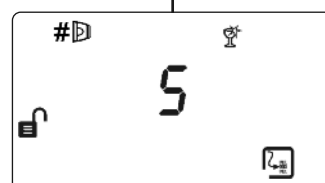

AGC value when the event occurred. If the AGC value could not be read during the event '—' will be displayed.

### 3. Troubleshooting - LASER not visible

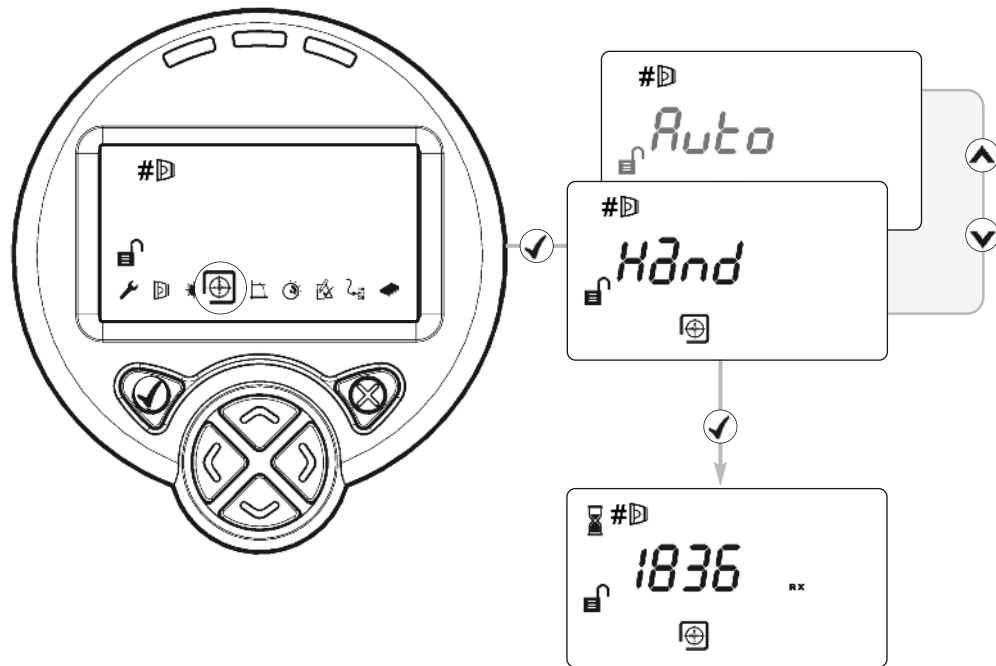

If it is not possible to see the LASER because of the installation environment (for example, if you cannot see the Reflector from the System Controller or there is high ambient light) then use 'Hand' Alignment. This option displays the signal strength value returned by the Detector, and allows the user to move the beam

1. Start 'Auto' Alignment and press **X** after two seconds to exit. (this will maximise infrared power)
2. Select 'Hand' alignment
3. Use **←** **→** **↑** **↓** to steer the beam until the signal strength is above 800. There is no auto-repeat function on any key. To move the motor in any given direction more than once, press the key multiple times
4. Cover the Reflector. If the Signal Strength does not drop by more than half, the beam is not aligned to the Reflector, so repeat Step 3
5. Perform 'Auto' alignment, followed by 'Set'

## 4. Troubleshooting - HOME

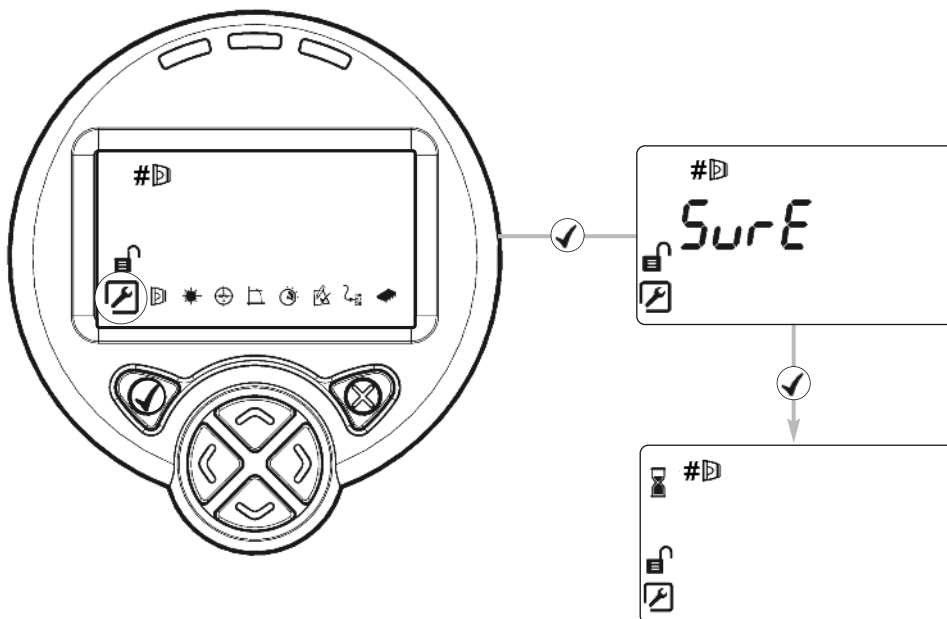

If it is not known where the beam is pointing, use Home Position to automatically steer the infrared beam to approximately the centre of its range of movement.

- Press ✓ or ✗ to exit this function
- This will take up to 3 minutes to complete
- When complete the display will return to the Engineering Menu

# 6. Display and Indicators - LCD Icon Layout

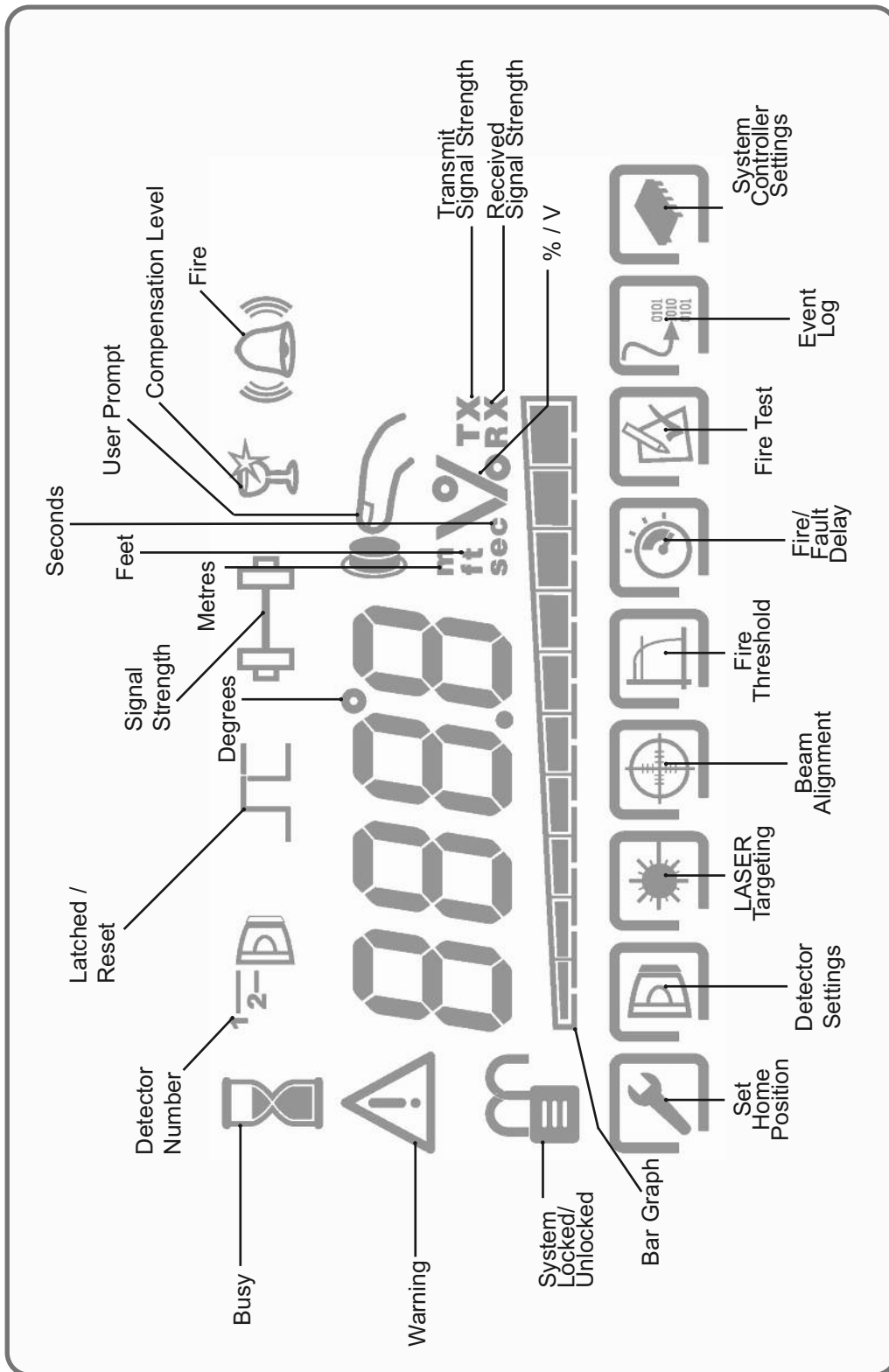



# 7. Display and Indicators - Detector and System Controller Status Indicators

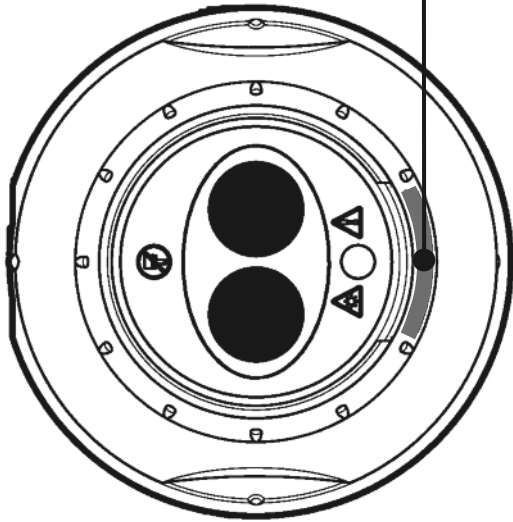

**Detector**  
Indicator flashes every 10 seconds.  
NORMAL: GREEN  
FAULT: YELLOW  
FIRE: RED

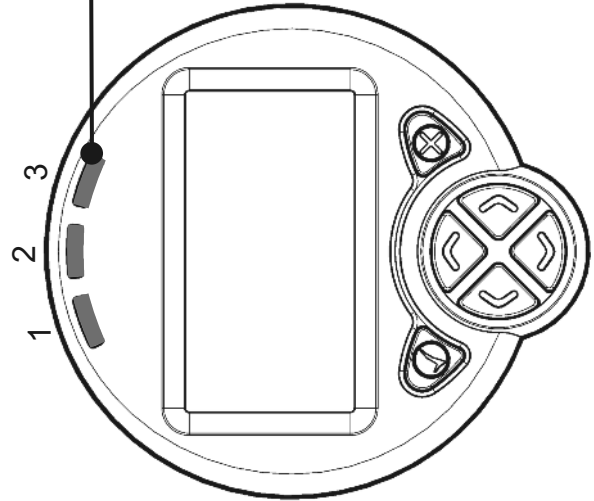

**System Controller**  
Indicators 1 to 2 show status for Detectors 1 to 2:  
NORMAL: No flash  
FAULT: YELLOW  
FIRE: RED  
Indicator 3 flashes GREEN to indicate NORMAL System Controller status.  
All indicators flash every 10 seconds.

# 8. Menu Layout - User Menu

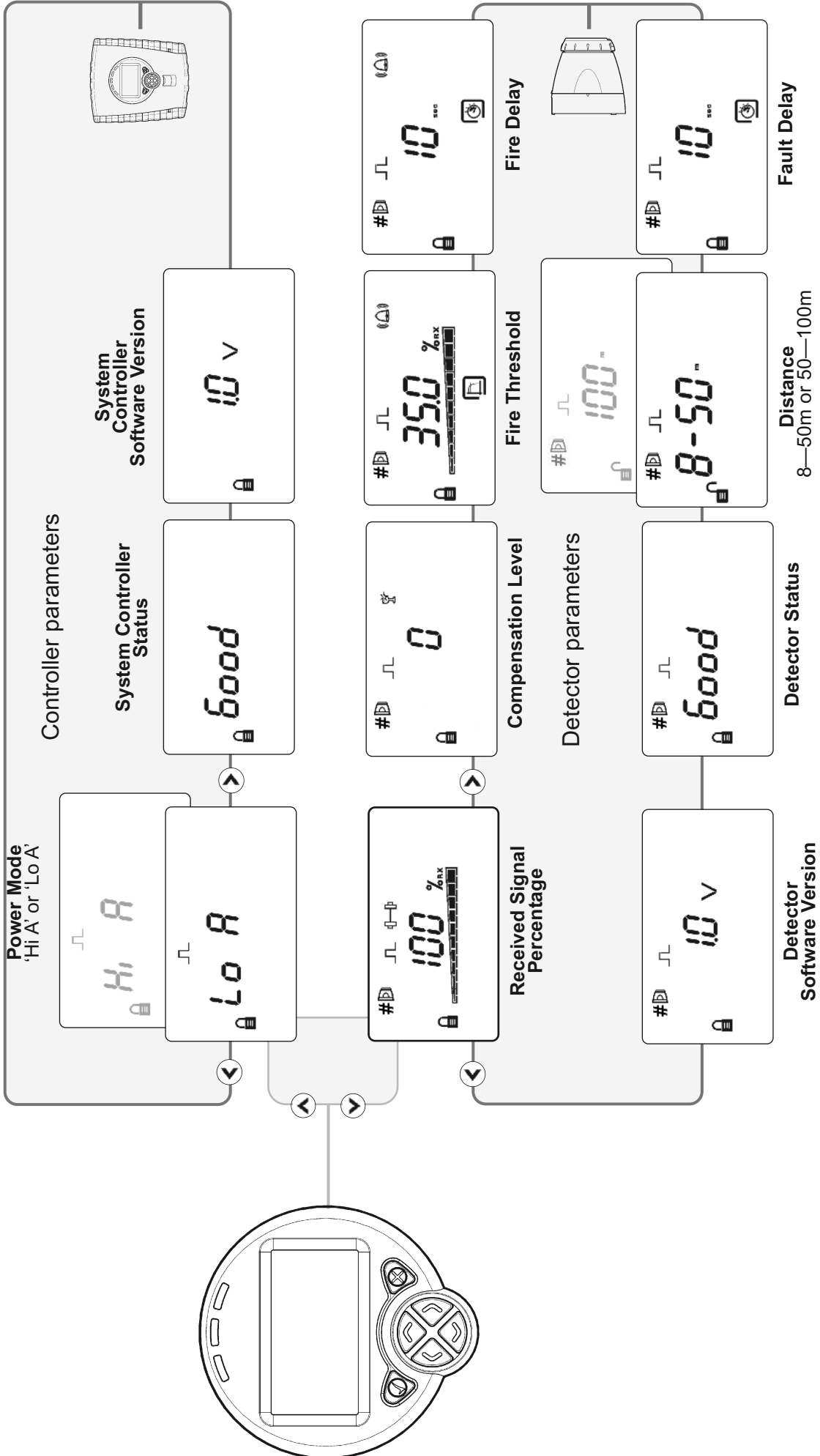

- Press **✓** in this menu to enter the Pass Code
- Press **✗** to put the system into Sleep

# 9. Menu Layout - Engineering Menu

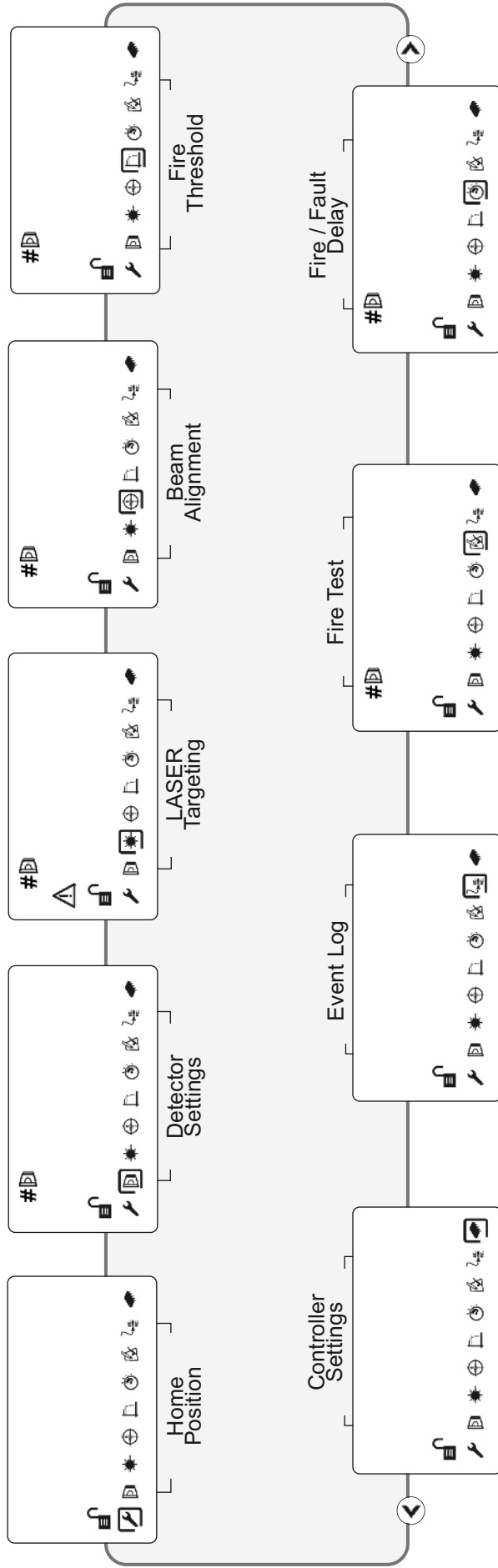

- The Pass Code must be entered to access the Engineering Menu
- The menu is navigated by using ⏪ ⏩ keys to move the cursor.
- Items are selected by using ✓
- Pressing ✖ exits this menu and returns the system to a 'locked' state

# 10. Menu Layout - Detector Settings

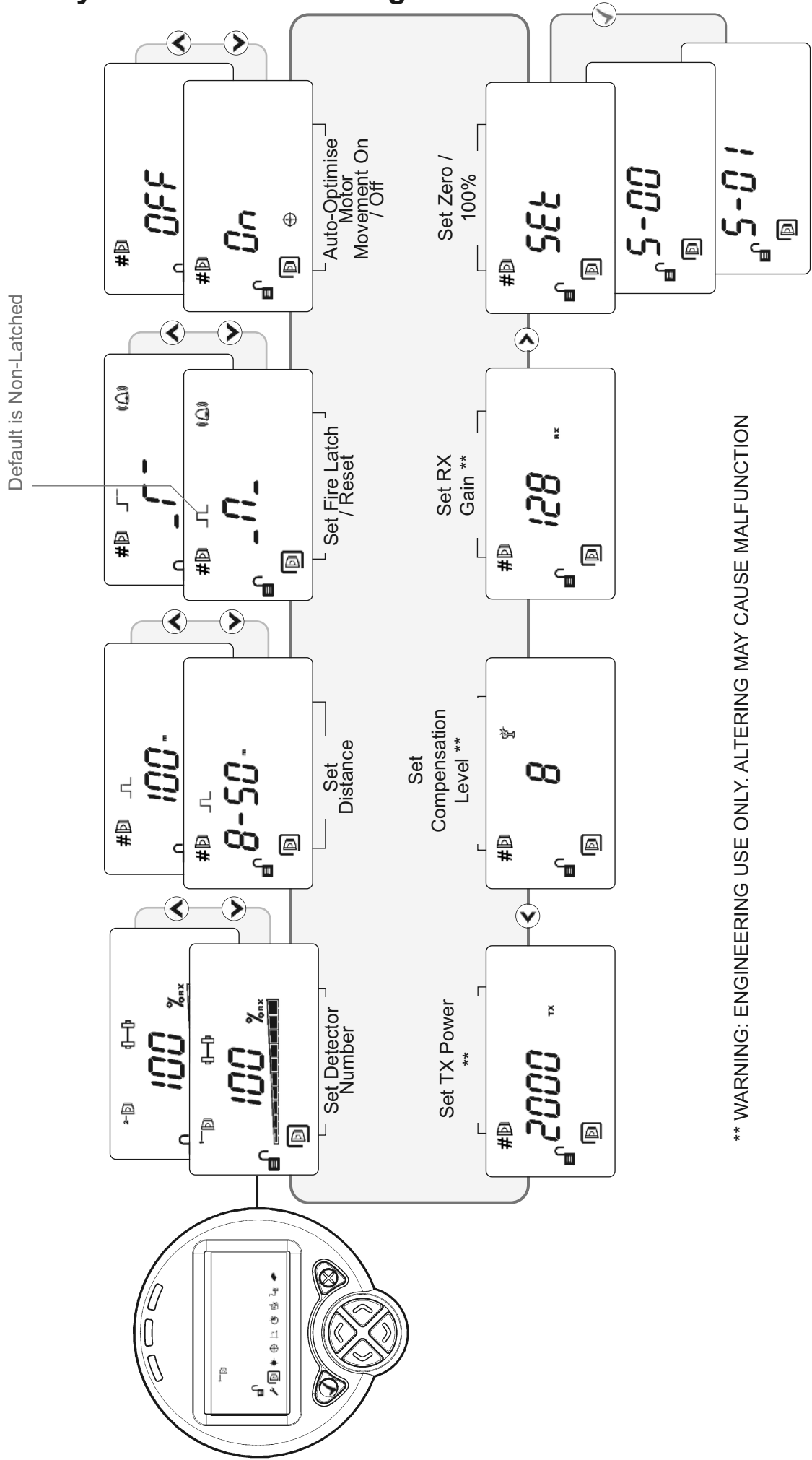

\*\* WARNING: ENGINEERING USE ONLY. ALTERING MAY CAUSE MALFUNCTION

# 11. System Controller Settings

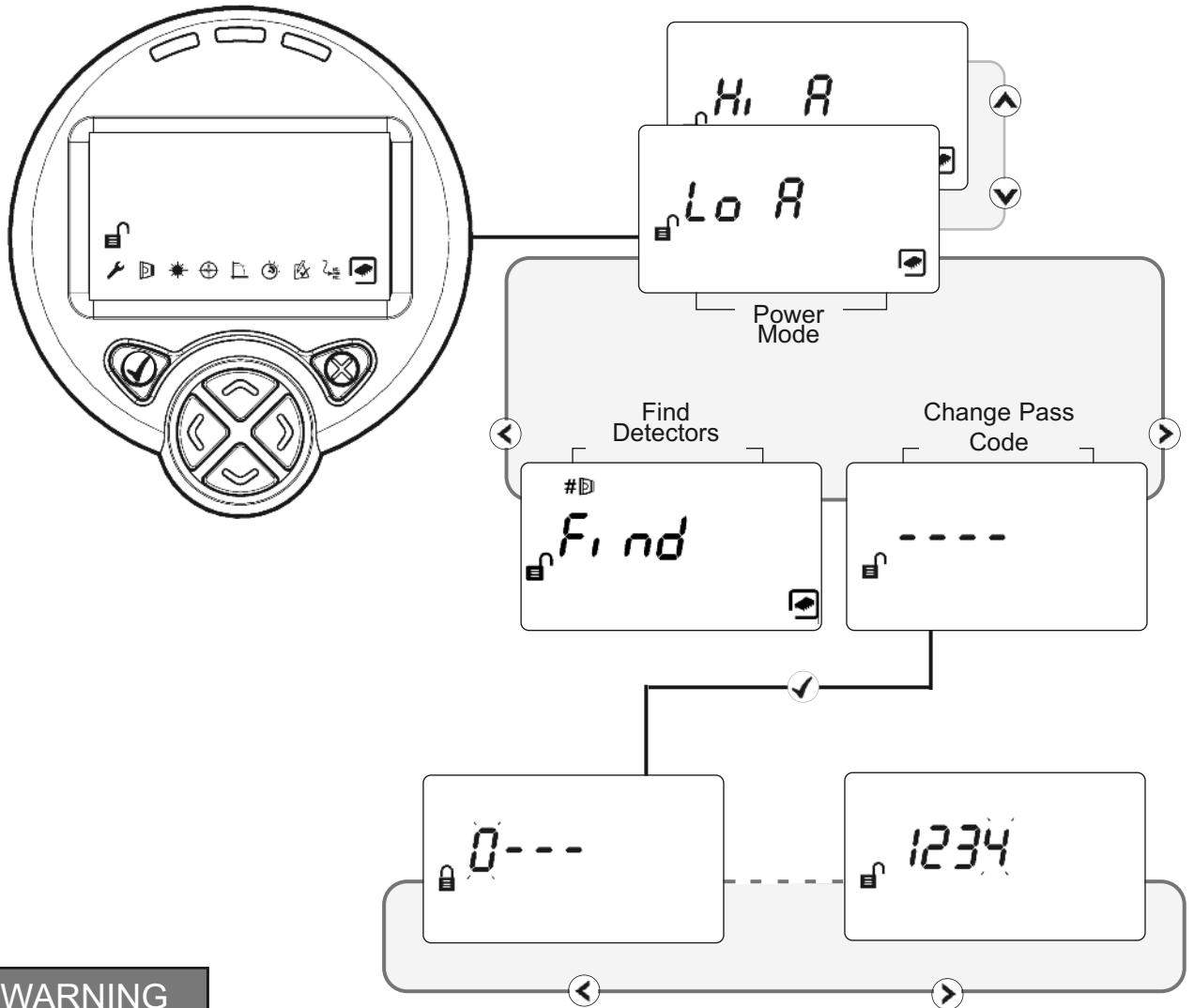

**WARNING**  
Care must be taken when changing the Pass Code. If the code is lost, contact the manufacturer for Pass Code reset.

### • Change Pass Code

Use ⬅ ➡ to access each digit

Use ▼ ▲ to change the digit

Press ✓ to save the new Pass Code and return to the settings menu

Press ✕ to cancel the change and return to the Engineering menu